

B50S001

Part Number

weQubeVision



- Image processing functions
- MultiCore technology

The vision sensor weQubeVision is based on the wenglor MultiCore technology. The functions autofocus, region of interest and tracking ensure optimal object detection. The following image processing modules are available: Dimensional accuracy check, sorting procedures, presence control, object counting, position output, pixel counting, filter options, and statistics evaluation. Thanks to the integrated color image chip, all image processing functions are also available for remote applications.

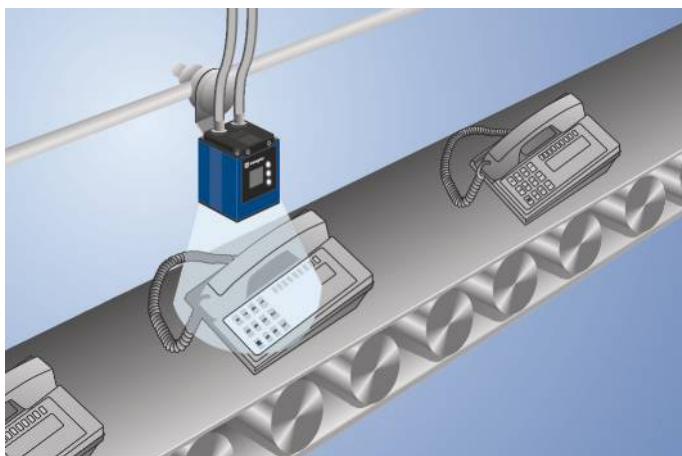

Technical Data

Optical Data	
Working Range	≥ 20 mm
Resolution	736 × 480 Pixel
Image Chip	color
Light Source	White Light
Service Life (T = +25 °C)	100000 h
Visual Field	see Table 1
Frame Rate	15 Hz

Electrical Data	
Supply Voltage	18...30 V DC
Current Consumption (U _b = 24 V)	< 200 mA
Response Time	66 ms
Temperature Range	-25...55 °C*
Inputs/Outputs	6
Switching Output Voltage Drop	< 2,5 V
Switching Output/Switching Current	100 mA
Short Circuit Protection	yes
Reverse Polarity Protection	yes
Interface	RS-232/Ethernet
Protection Class	III

Mechanical Data	
Setting Method	Ethernet
Housing Material	Aluminum
Degree of Protection	IP67
Connection	M12 × 1; 12-pin
Type of Connection Ethernet	M12 × 1; 8-pin, X-cod.

Safety-relevant Data	
MTTFd (EN ISO 13849-1)	227,7 a

Function	
Presence Check	yes
Pixel Comparison	yes
Reference Image Comparison	yes
Tracking	yes
Object detection	yes
Dimensional accuracy check	yes

Web server	yes
------------	-----

Configurable as PNP/NPN/Push-Pull	●
Switchable to NC/NO	●
Illumination Output	●
RS-232 Interface	●
Ethernet	●

Connection Diagram No.	002 1008
Control Panel No.	X2
Suitable Connection Equipment No.	50 87
Suitable Mounting Technology No.	560

Display brightness may decrease with age. This does not result in any impairment of the sensor function.
 * -25 °C: Ambient conditions should not result in condensation; avoid the formation of ice on the front panel!
 55 °C: Continuous illumination at max. 1% or flash mode at 100% brightness with an exposure time of ≤ 5 ms; may affect the service life of the product.

Complementary Products

Disk with Polarization Filter ZNNG004
Illumination Technology
License Upgrade, weQube Pattern Matching DNNL006
Protective Housing ZNNS001, ZNNS002
Software
weQubeDecode License Upgrade DNNL002
weQubeOCR License Upgrade DNNL003

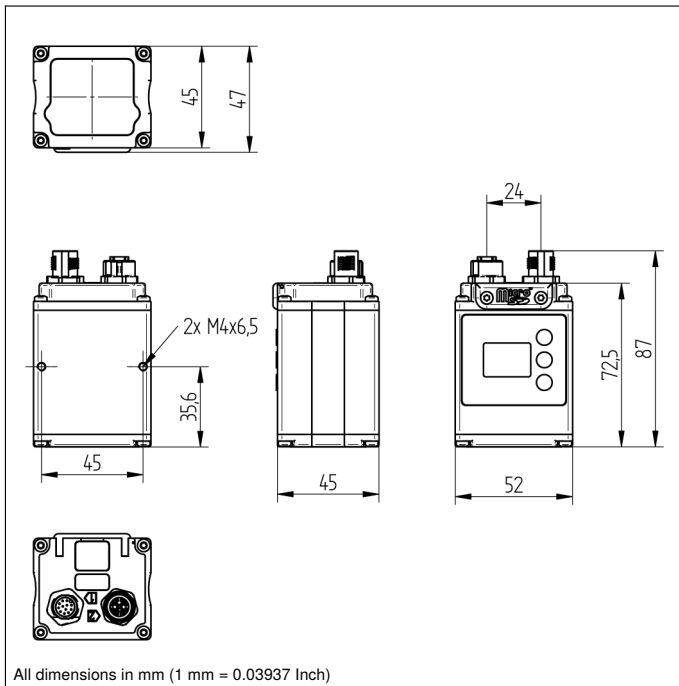

Ctrl. Panel

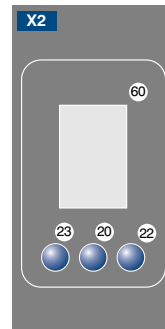

20 = Enter Button
 22 = UP Button
 23 = Down Button
 60 = Display

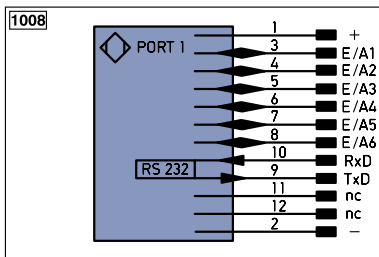
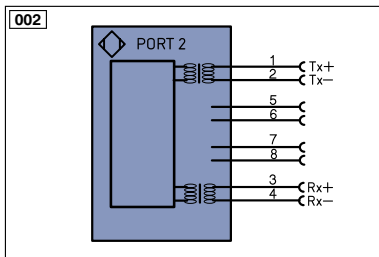

Legend

+	Supply Voltage +	PT	Platinum measuring resistor	EN _A EN ₅₄₂₂	Encoder A/ \bar{A} (TTL)
-	Supply Voltage 0 V	nc	not connected	EN _B EN ₅₄₂₂	Encoder B/ \bar{B} (TTL)
~	Supply Voltage (AC Voltage)	U	Test Input	EN _A	Encoder A
A	Switching Output (NO)	U	Test Input inverted	EN _B	Encoder B
\bar{A}	Switching Output (NC)	W	Trigger Input	A _{MIN}	Digital output MIN
V	Contamination/Error Output (NO)	W-	Ground for the Trigger Input	A _{MAX}	Digital output MAX
\bar{V}	Contamination/Error Output (NC)	O	Analog Output	A _{OK}	Digital output OK
E	Input (analog or digital)	O-	Ground for the Analog Output	SY _{In}	Synchronization In
T	Teach Input	BZ	Block Discharge	SY _{OUT}	Synchronization OUT
Z	Time Delay (activation)	AWV	Valve Output	OLT	Brightness output
S	Shielding	a	Valve Control Output +	M	Maintenance
RxD	Interface Receive Path	b	Valve Control Output 0 V	rsv	reserved
TxD	Interface Send Path	SY	Synchronization	Wire Colors according to IEC 60757	
RDY	Ready	SY-	Ground for the Synchronization	BK	Black
GND	Ground	E+	Receiver-Line	BN	Brown
CL	Clock	S+	Emitter-Line	RD	Red
E/A	Output/Input programmable	⊕	Grounding	OG	Orange
	IO-Link	S _n R	Switching Distance Reduction	YE	Yellow
PoE	Power over Ethernet	Rx+/-	Ethernet Receive Path	GN	Green
IN	Safety Input	Tx+/-	Ethernet Send Path	BU	Blue
OSSD	Safety Output	Bus	Interfaces-Bus A(+)/B(-)	VT	Violet
Signal	Signal Output	L _a	Emitted Light disengageable	GY	Grey
Bl_D+/-	Ethernet Gigabit bidirect. data line (A-D)	Mag	Magnet activation	WH	White
EN ₀ EN ₅₄₂₂	Encoder 0-pulse 0-0 (TTL)	RES	Input confirmation	PK	Pink
		EDM	Contactur Monitoring	GNYE	Green/Yellow

Table 1

Working Distance	20 mm	100 mm	200 mm
Visual Field	24 × 16 mm	74 × 48 mm	145 × 94 mm

