



### Special features

- For general purpose
- Strain gauge measuring system
- Compression
- Made of high-grade stainless steel or aluminium (0.1 – 0.5 kN)
- Low profile
- Application:
  - Industry
  - Testing machines
  - Laboratory

### Specifications

Rated capacity (F <sub>n</sub> )	0.1, 0.2, 0.5	1, 2, 5	10, 20, 50	100, 200, 500	kN
Overload					
- Safe					130
- Ultimate					150
- Permanent static load <sup>1</sup>					75
- Dynamic load <sup>1</sup>					50
Nominal sensitivity (C <sub>n</sub> )	1.0 ± 2 %	1.5 ± 2 %			mV/V
Zero balance	2				% F.S.
Non-linearity	0.25	0.5	1.0		% F.S.
Hysteresis	0.25	0.5	1.0		% F.S.
Creep (30 min)	0.1				% F.S.
Temperature effect					
- On zero					0.1
- On output					0.1
Bridge resistance					
- Input					380 ± 10 %
- Output					350 ± 5 %
Insulation Impedance	> 5000				MΩ
Excitation <sup>2</sup>					
- Recommended	5	10		V	
- Maximal	7	15		V	
Temperature range					
- Compensated	0 ... + 50				°C
- Operating	- 10 ... + 70				°C
Protection	IP54				
Cable					
- Type	LiFYDY 4 x 0.05		LiYCY 4 x 0.14		
- Length	2		2		m

Notes:

- 1 Recommended value
- 2 DC or AC Voltage

## Outline dimensions

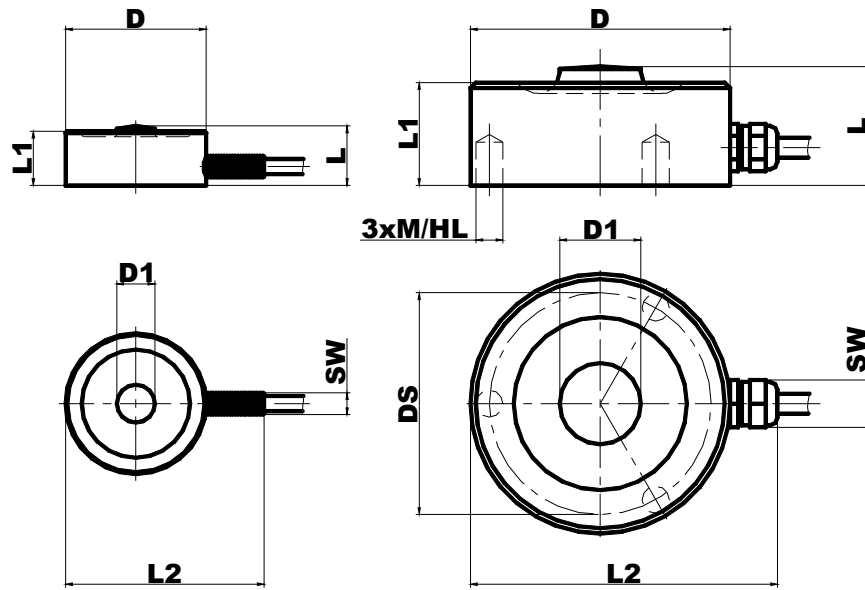

0.1 ... 50 kN

100 ... 500 kN

F <sub>n</sub> <sup>1</sup> (kN)	Dimensions in mm									
	D	DS	D1	L	L1	L2	SW	M / HL	Mass kg	Deflection @ F <sub>n</sub> (μm)
0.1	32	28	7	11	10	40	Φ4	M3 / 5	0.04	30
0.2	32	28	7	11	10	40	Φ4	M3 / 5	0.04	30
0.5	32	28	7	11	10	40	Φ4	M3 / 5	0.04	30
1	32	28	7	11	10	40	Φ4	M3 / 5	0.07	30
2	32	28	7	11	10	40	Φ4	M3 / 5	0.07	30
5	32	28	7	11	10	40	Φ4	M3 / 5	0.07	30
10	36	32	8	16	15	44	8	M3 / 5	0.10	50
20	40	35	10	19	17	50	8	M4 / 6	0.14	50
50	48	41	15	22	19	58	8	M5 / 8	0.22	60
100	60	50	20	26	22	70	11	M6 / 10	0.43	100
200	74	61	28	31	26	84	11	M8 / 12	0.80	100
500	110	87	44	42	36	120	11	M10 / 16	2.50	150

## Wiring color code

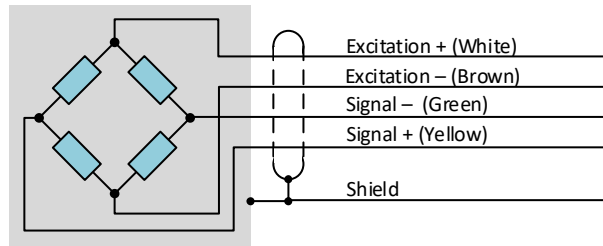

## Sensor output characteristic

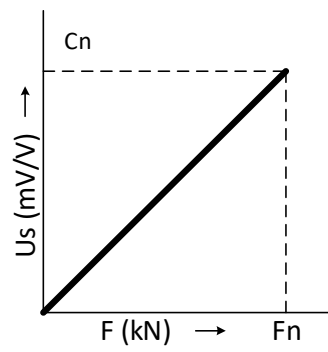

# Wiring diagram, connection example to EMS169 signal conditioner

Note: The signal conditioner setting is described in the signal conditioner documentation

**Load compression, signal conditioner output positive (0...+10 V, 4...20 mA)**

## Wiring diagram

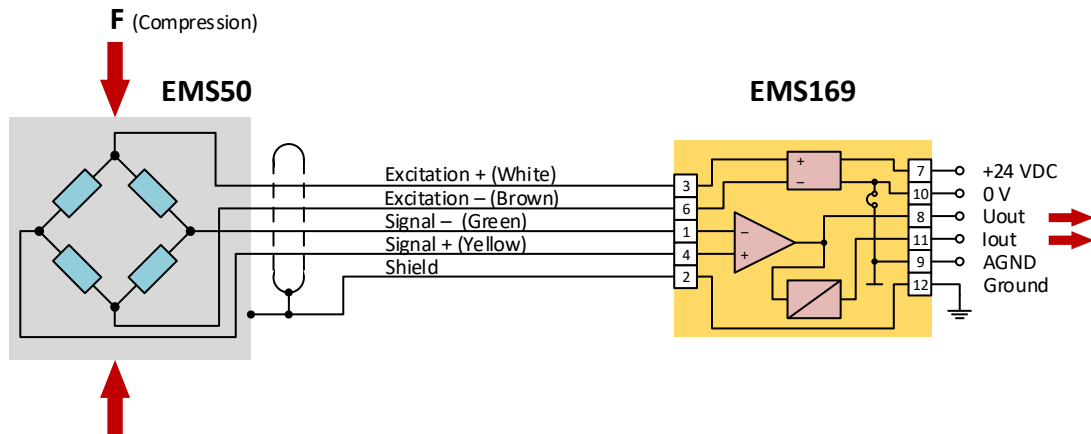

## System output characteristic

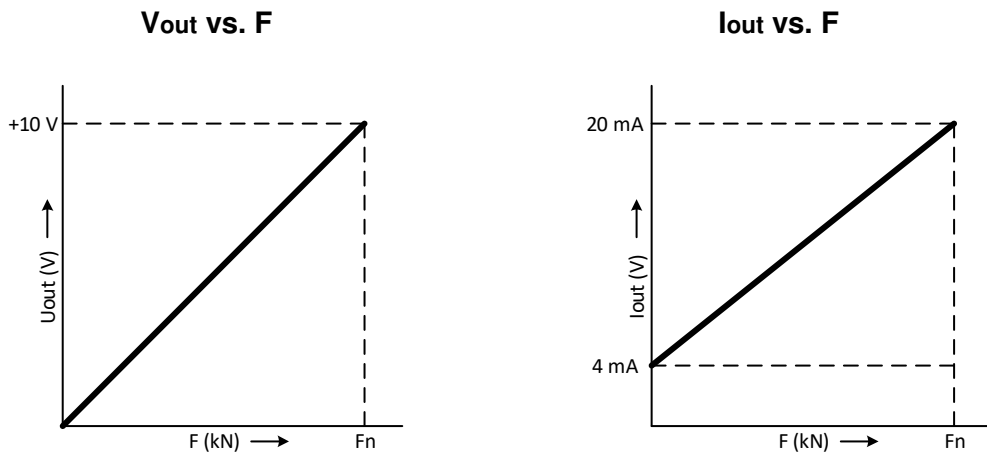

# Parallel wiring diagram

