



Special features

- For general purpose
- Strain gauge measuring system
- Tension / Compression
- Made of high-grade stainless steel or aluminium (0.05 – 0.5 kN)
- Small dimensions
- Application:
 - Industry
 - Testing machines
 - Laboratory

Specifications

Rated capacity (F _n)	0.05	0.1, 0.2, 0.5	1, 2, 5	kN
Overload				
- Safe	130			% F _n
- Ultimate	150			% F _n
- Permanent static load ¹	75			% F _n
- Dynamic load ¹	50			% F _n
Nominal sensitivity (C _n)	1.0 ± 2 %		1.5 ± 2 %	mV/V
Zero balance	2			% F.S.
Non-linearity	0.5	0.25		% F.S.
Hysteresis	0.5	0.25		% F.S.
Creep (30 min)	0.2	0.1		% F.S.
Temperature effect				
- On zero	0.1			% F.S./10 °C
- On output	0.1			% F.S./10 °C
Bridge resistance				
- Input	395 ± 10 %		380 ± 10 %	Ω
- Output	350 ± 5 %		350 ± 5 %	Ω
Insulation Impedance	> 5000			MΩ
Excitation ²				
- Recommended	5 ... 7		7 ... 10	V
- Maximal	10		15	V
Temperature range				
- Compensated	0 ... + 50			°C
- Operating	- 10 ... + 70			°C
Protection	IP54			
Construction	Aluminium		Steel	
Cable				
- Type	LifYDY 4 x 0.05			
- Length	2			m

Notes:

1 Recommended value

2 DC or AC Voltage

Outline dimensions

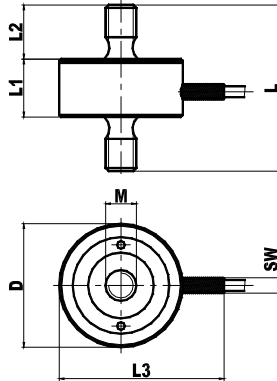

Rated capacity F_n (kN)	D mm	M mm	L mm	L1 mm	L2 mm	L3 mm	SW mm	Mass kg	Deflection, @ F_n (μm)
0.05	18	M4	24	10	7	24	Φ 3	0.04	35
0.1	28	M6	34	14	10	38	Φ 4	0.05	35
0.2	28	M6	34	14	10	38	Φ 4	0.05	35
0.5	28	M6	34	14	10	38	Φ 4	0.05	35
1	32	M8	43	15	14	42	Φ 4	0.1	45
2	32	M8	43	15	14	42	Φ 4	0.1	45
5	32	M8	43	15	14	42	Φ 4	0.1	45

Sensor wiring color code

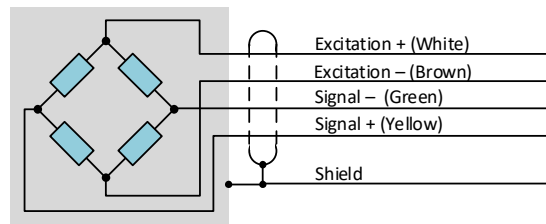

Sensor output characteristic

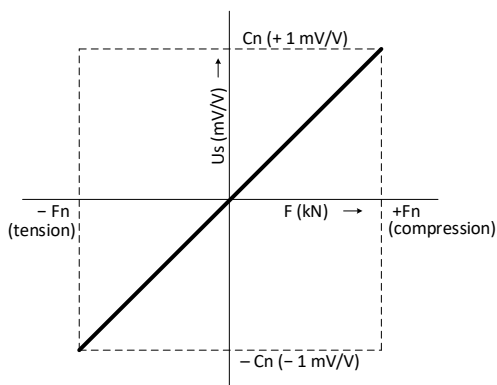

F_n (kN): 0.05, 0.1, 0.2, 0.5

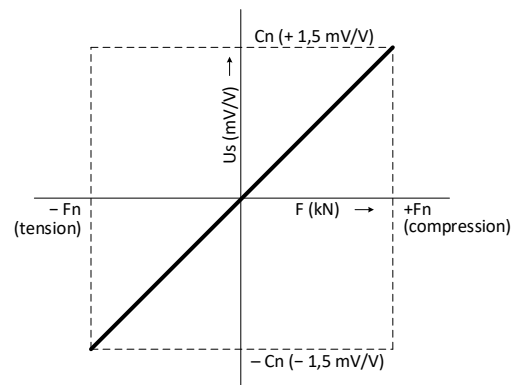

F_n (kN): 1, 2, 5

Wiring diagram, connection example to EMS169 signal conditioner

Note: The signal conditioner setting is described in the signal conditioner documentation

1. Load compression, signal conditioner output positive (0...+10 V, 4...20 mA)

Wiring diagram

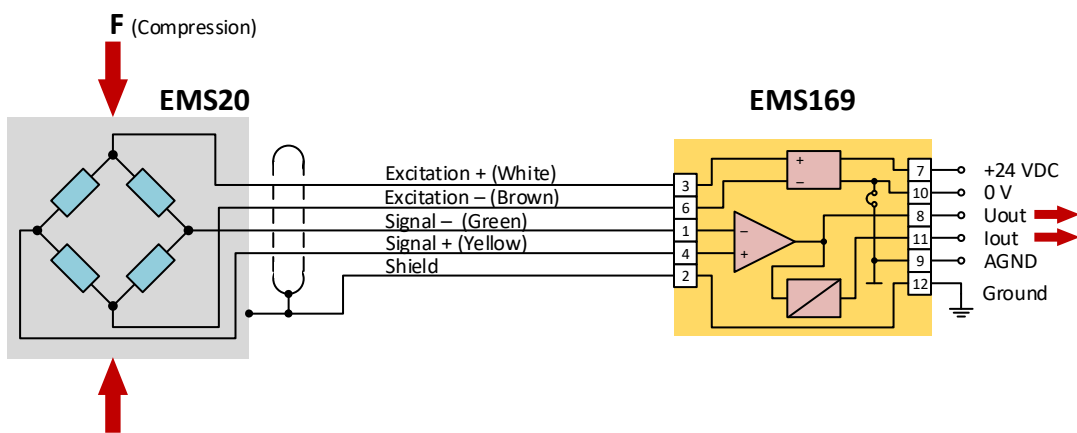

System output characteristic

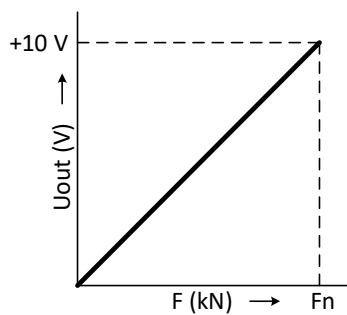

U_{out} vs. F

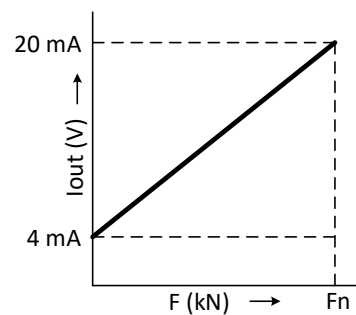

I_{out} vs. F

2. Load tension, signal conditioner output positive (0...+10 V, 4...20 mA)

Wiring diagram

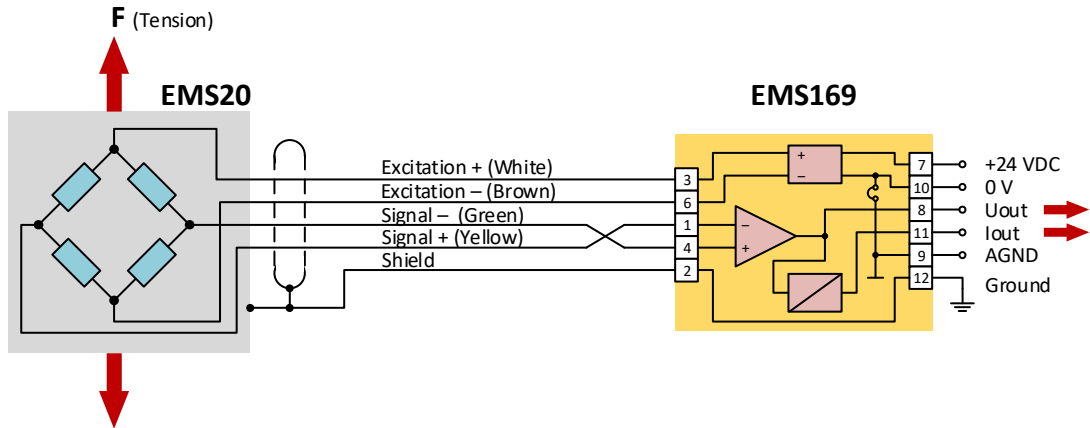

System output characteristic

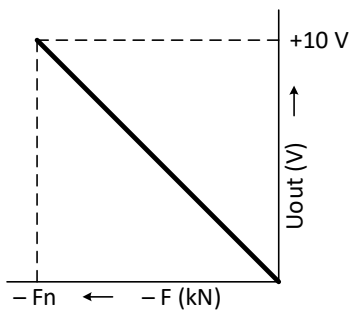

U_{out} vs. F

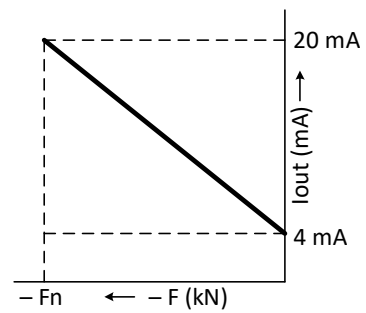

I_{out} vs. F

3. Load compression and tension, signal conditioner output bipolar (-10 V ... 0...+10 V)

Note: The current output does not work in the negative range.

Wiring diagram

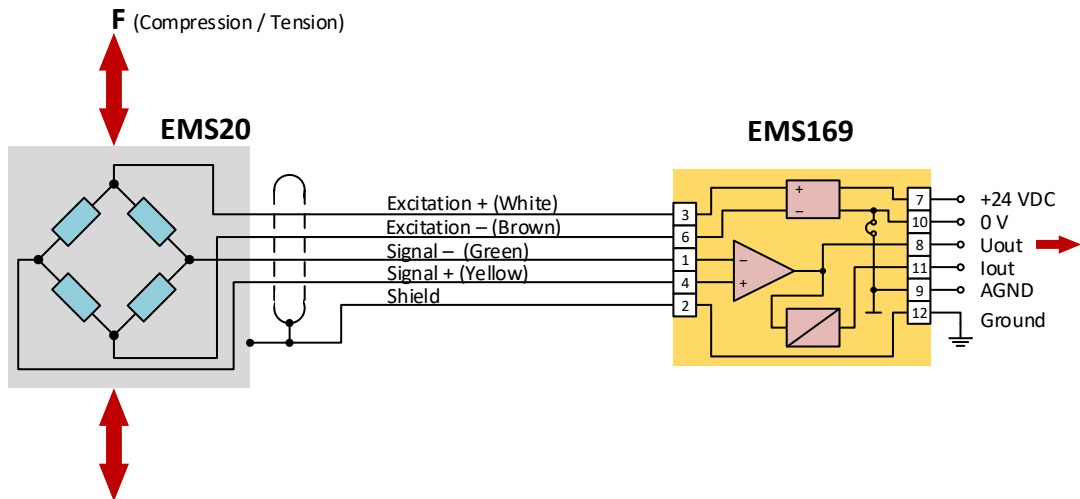

System output characteristic

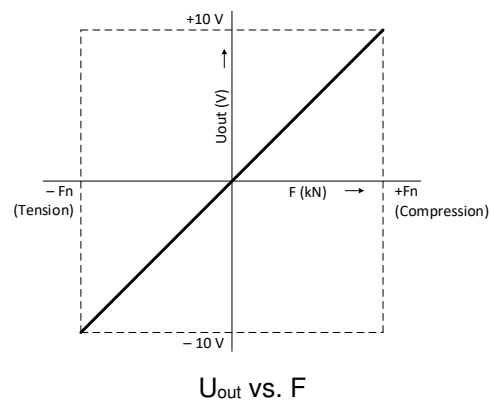

4. Load compression and tension, signal conditioner output positive (0...+10 V, 4...20 mA)

Wiring diagram

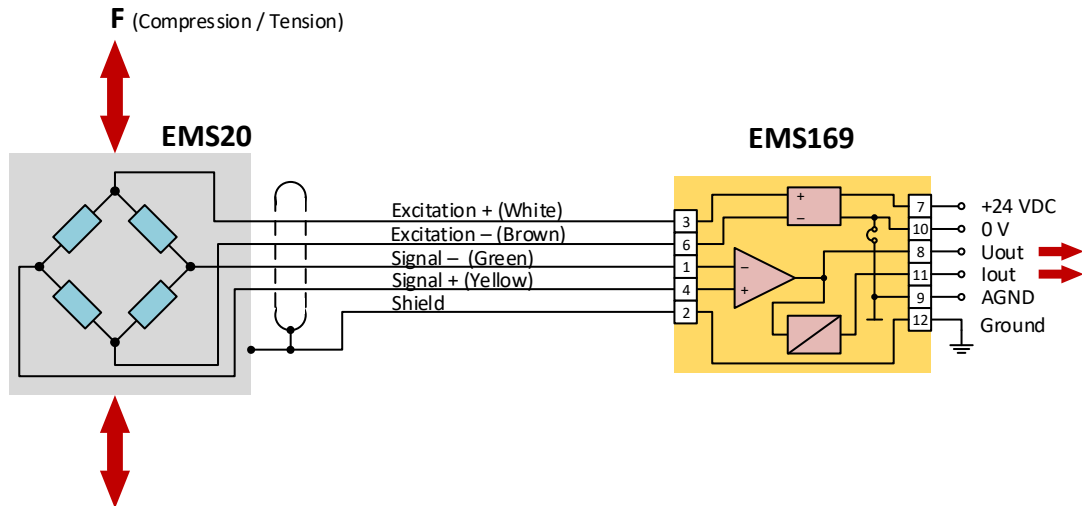

System output characteristic

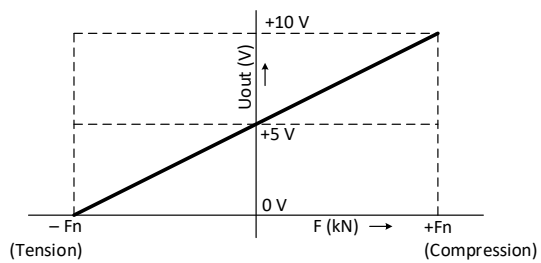

U_{out} vs. F

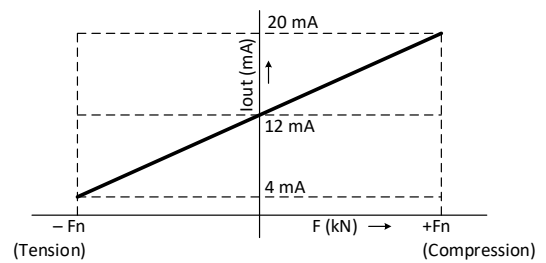

I_{out} vs. F

Parallel wiring diagram

