

Data Sheet for Joysticks

Finger Joystick

Series TRY100



- Good cost/performance ratio
- Shallow installation depth < 26 mm
- Service-friendly due to connectors
- Optional with redundant Hall sensors
- Available interfaces include USB, CAN-bus J1939 and CANopen
- Ideally suited for applications in CCTV, robotics, medical technology and audio/video productions

The TRY100 is the all-rounder in the field of finger joysticks because of the extensive selection of handles, limiters and output options. It offers conventional handle designs as well as modern look & feel variants, in addition analogue outputs and digital interfaces. Thus the joysticks can be optimized for almost all possible applications.

Technical Data

Sensor technology	Hall Effect
Supply Voltage*	5.0 ± 0.5 VDC transient free
Voltage in Center Position*	2.5 V
Return to Center Accuracy	±200 mV (valid for output voltage span of 0 to 5 V without load)
Output Linearity	±200 mV
Output Impedance	2 Ohm
Load Resistance	Min. 1 kOhm, recommended > 100 kOhm
Expected Life	5 million cycles
Output Voltages	0 to 5 V / 0.5 to 4.5 V / 0.25 to 4.75 V / for others see description on page 2
Supply Current	typ. 40 mA / max. 50 mA (3 axes)
Angle of Movement X-, Y-Axis / Z-Axis	36° (±18° from center) / 60° (±30° from center)
Operating Force X-Y-Axis	typ. 2.8 N / Break Out Force 1.3 N / max. applied: 200 N
Operating Force Z-Axis	0.12 Nm / Break Out Force 0.09 Nm / max. applied: 2.5 Nm
Max. vertical Load to Mechanism	200 N
Operating / Storage Temperature	-40 °C to +70 °C / -40 °C to +70 °C
Above Panel Sealing	Up to IP67 (depending on handle type)
Panel Thickness	1.17 to 3.17 mm (max. 1.6 mm for Rear Mount option)
EMC Immunity Level (V/M)	EN61000-4-3
EMC Emissions Level	EN61000-6-3:2001
ESD	EN61000-4-2

*The output voltage is ratiometric to the supply voltage. We therefore suggest to use low-noise, stabilized power supplies.

Wiring

Pin	Function	Colour	Pin	Function	Colour
1	Ground	black	7	Z-Axis Dual Output	grey (<i>old: green/black</i>)
2	Power	red	8	Z-Axis	green
3	X-Axis Dual Output	pink (<i>old: blue/white</i>)	9	Pushbutton 1	orange
4	X-Axis	blue	10	Pushbutton 1/2 Common	white
5	Y-Axis Dual Output	brown (<i>old: yellow/black</i>)	11	Pushbutton 2	violet
6	Y-Axis	yellow	12	n.c.	n.c.

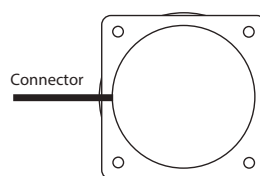
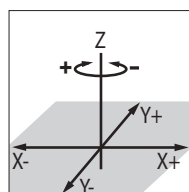

Data Sheet for Joysticks

Finger Joystick

Series TRY100

Please contact us for information regarding stock articles, delivery times and minimum order quantities.

Order Description / Options

Description	Selection: standard=black/bold, possible options=grey/italics							
Series	TRY100							
Axis:								
2 Axes, with Pushbutton in handle	3							
3 Axes	4							
3 Axes, with Pushbutton(s) in handle	5							
2 Axes	2							
1 Axis	1							
1 Axis with Pushbutton in handle	6							
Sealing:								
Rubber Boot		5						
Return Mechanism:								
Spring Return			1					
Handles:								
Handle 4, for 1-2 Axis, 1 Pushbutton, IP55					4			
Handle 6, for 3 Axes, Low Profile, w/o Pushbutton, IP55					6			
Handle 9, for 3 Axes, 1 Pushbutton, IP55					9			
Handle A, for 3 Axes, 2 Pushbuttons, IP55					A			
Handle E, for 3 Axes, 2 Pushbuttons, IP67					E			
Handle 7, for 3 Axes, w/o Pushbutton, IP55					7			
Handle 1, Tapered (not compatible to mounting 2), IP67					1			
Handle 3, Ball Tip, IP67					3			
Handle 5, for 1-2 Axis, 1 Pushbutton, IP67					5			
Handle B, for 3 Axes, w/o Pushbutton, IP67					B			
Handle C, for 3 Axes, 1 Pushbutton, IP67					C			
Handle D, for 3 Axes, 2 Pushbuttons, IP67					D			
Limiters:								
Square					1			
Round					3			
Plus "+ X/Y					9			
Slotted X -					7			
Slotted Y					8			
Square "guided feel"					4			
Round "guided feel"					5			
Output Signal:								
0 to 5.0V (redundant signals parallel / inverse ⁽¹⁾)						1 (1P / 1X)		
0.5 to 4.5V (redundant signals parallel / inverse ⁽²⁾)						2 (2P / 2X)		
0.25 to 4.75V (redundant signals parallel / inverse ⁽³⁾)						3 (3P / 3X)		
USB						5		
USB Mouse Emulation						6		
CANbus J1939						7		
CANopen with baud rate 125 kbit/s						8A		
CANopen with baud rate 250 kbit/s						8B		
CANopen with baud rate 500 kbit/s						8C		
CANopen with baud rate 1 Mbit/s						8D		
Voltage Regulator (see below)						0		
Mounting / Housing								
Drop-In							1	
Rear Mount							2	
Desktop-Housing w/o Pushbuttons							M0	
Desktop-Housing w/ 2 small Pushbuttons							M2	
Desktop-Housing w/ 2 long Pushbuttons							M2L	
Desktop-Housing w/ 3 small Pushbuttons							M3S	
Desktop-Housing w/ 4 small Pushbuttons							M4	
Desktop-Housing w/ 4 small Pushbuttons							M4D	
Desktop-Housing w/ 5 small Pushbuttons							M5	
Voltage Regulator ⁽⁴⁾								
Supply +12 to +30 VDC, Output 0 to +5 VDC								V1205
Supply +12 to +30 VDC, Output ±10 VDC								V1210B

⁽¹⁾ Output signals parallel: 0 to 5 V / 0 to 5 V; output signals inverse: 0 to 5 V / 5 to 0 V

⁽²⁾ Output signals parallel: 0.5 to 4.5 V / 0.5 to 4.5 V; output signals inverse: 0.5 to 4.5 V / 4.5 to 0.5 V

⁽³⁾ Output signals parallel: 0.25 to 4.75 V / 0.25 to 4.75 V; output signals inverse: 0.25 to 4.75 V / 4.75 to 0.25 V

⁽⁴⁾ The switching power supply for the electronics of this device requires an initial current of at least 100 mA.

The use of power supply units with current limiters operating below this threshold can damage the circuitry of the joystick!

Data Sheet for Joysticks

Finger Joystick

Series TRY100

For higher quantities or on-going demand, additional options are available

For example:

- Redundant output signals (inverted or parallel)
- Increased return-to-center spring tension
- Voltage regulator
- Customer-specific cables

Limiters

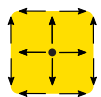

Square - Option "1"



1-axis "X" - Option „7“

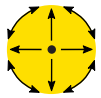

Round - Option "3"



1-axis "Y" - Option „8“

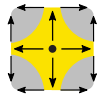

Square "guided feel" ⁽¹⁾ - Option "4"



X/Y Plus "+" - Option „9“

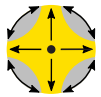

Round "guided feel" ⁽¹⁾ - Option "5"



X/Y Cross "x" - Option „D“

⁽¹⁾ "guided feel" still allows the joystick handle to be deflected omni-directionally, but as the operation force needed for the main axes is slightly below the force needed for diagonal deflection the resulting impression is that of a „guided movement“.

Connection cable

For ratiometric output a suitable cable (length approx. 25 cm) with Hirose DF11-12DS-2C connector is available (Art.nr. 129802, not included).

Other connectors and cable lengths available on request.

For Joysticks with USB interface the cable is included (please refer to chapter „USB Options“).



USB Options

USB Interface (USB 1.1 HID compatible)

The USB Controller is integrated into the Joystick. Power Supply will be provided by the USB host via the connection cable. This USB interface supports most versions of Microsoft Windows and Linux OS.

Cable included: USB cable (length approx. 1.75 m) with USB male type A connector. Other connectors and cable lengths available on request.

With integrated USB controller a maximum of 4 pushbuttons (handle + desktop housing) can be controlled. Please do not hesitate to contact us if you need a different configuration for your project.

USB Joystick as Mouse replacement

Cursor emulation optionally available. Supported protocols include Sun Microsystems (mouse systems 5 VDC serial) and USB (most versions of Microsoft Windows and Linux OS).

Handle versions

Handle 1



Drop-In mounting only

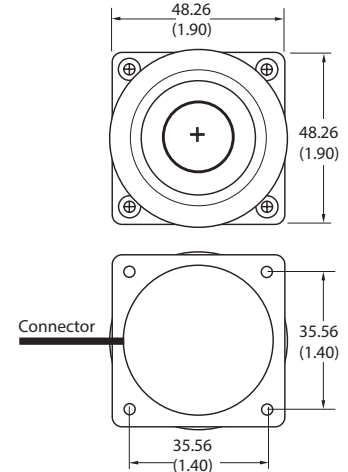
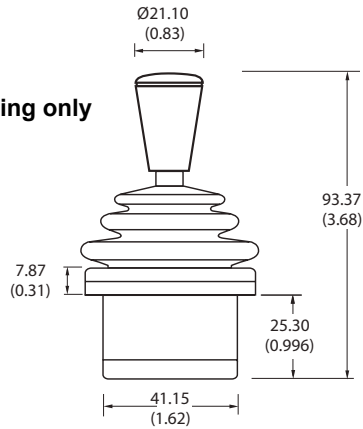

Handle 3

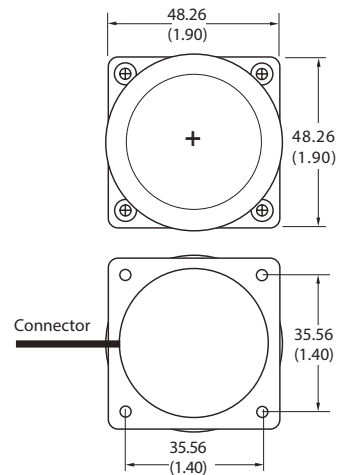
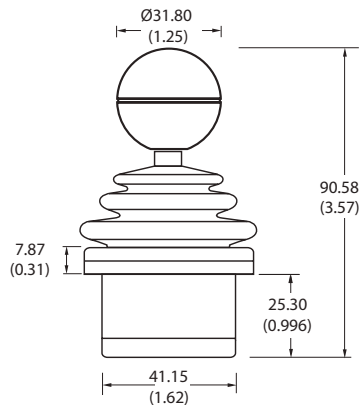

Handle 4

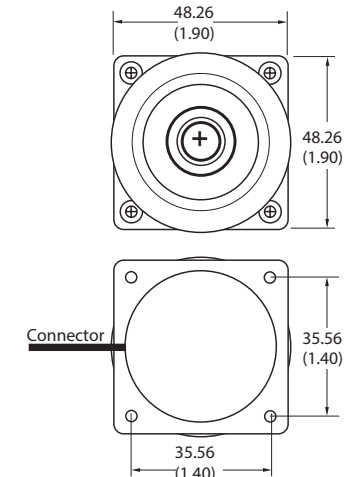
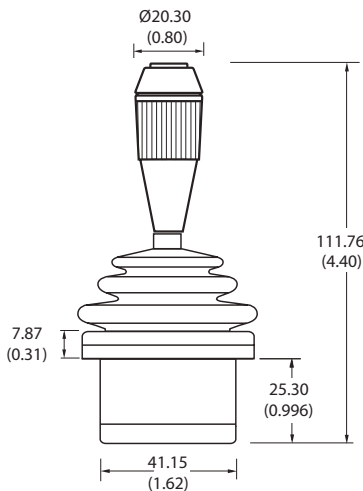

All dimensions in mm (inches)

Handle versions

Handle 5

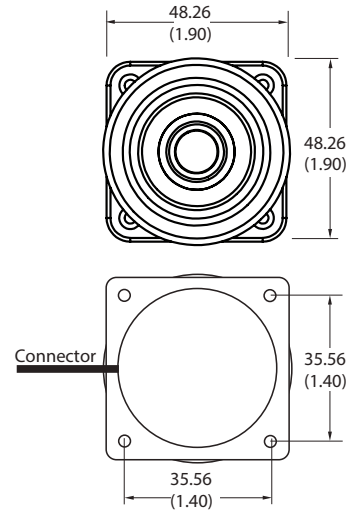
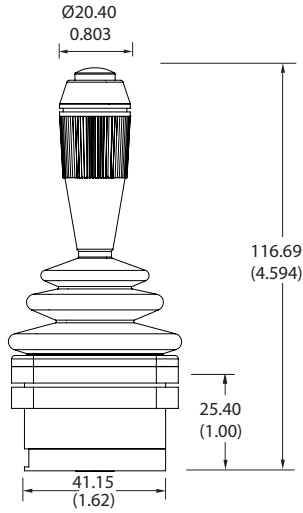

Handle 6

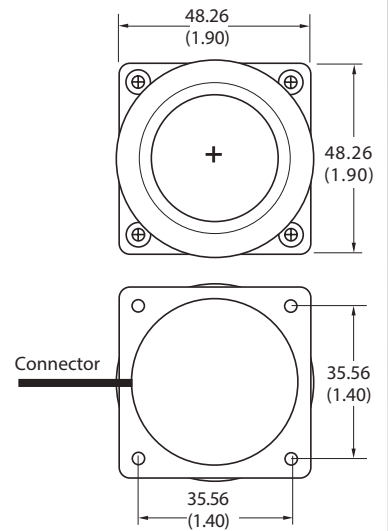
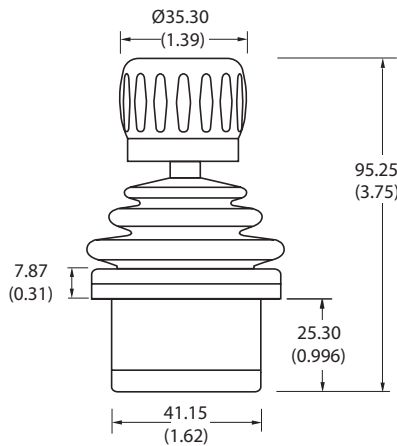

Handle 7

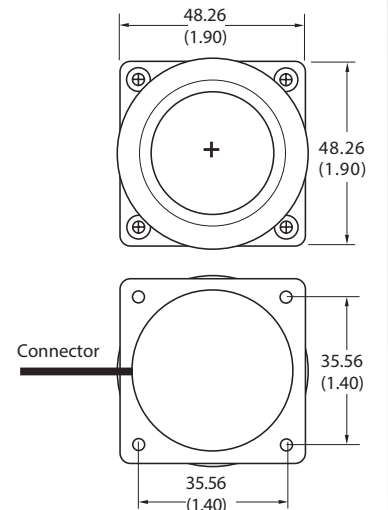
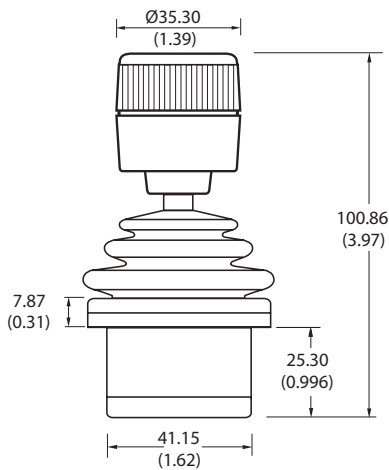

All dimensions in mm (inches)

Data Sheet for Joysticks

Finger Joystick

Series TRY100

Handle versions

Handle 9

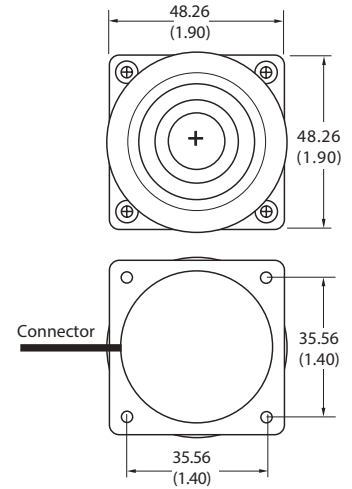
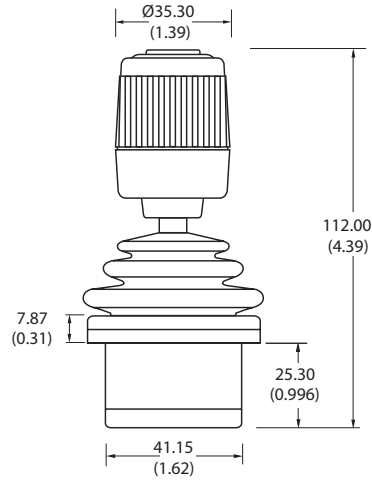

Handle A

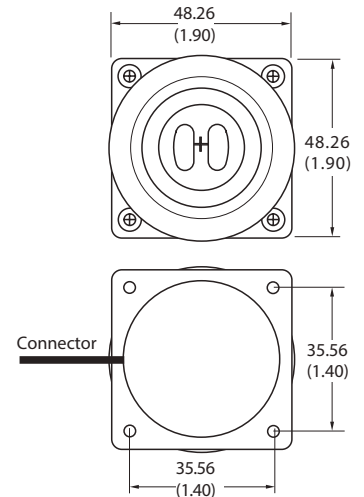
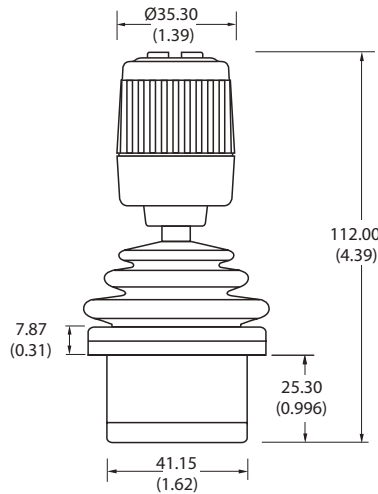

Handle B

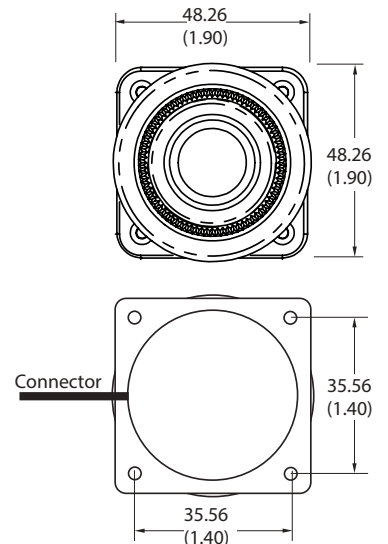
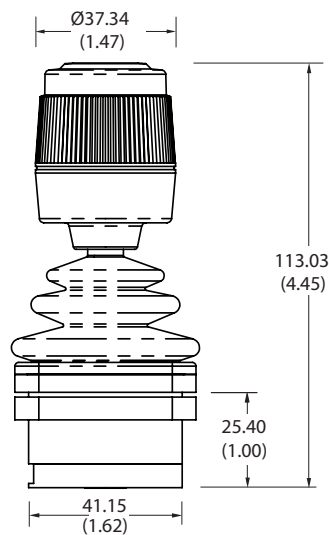

All dimensions in mm (inches)

Handle versions

Handle C

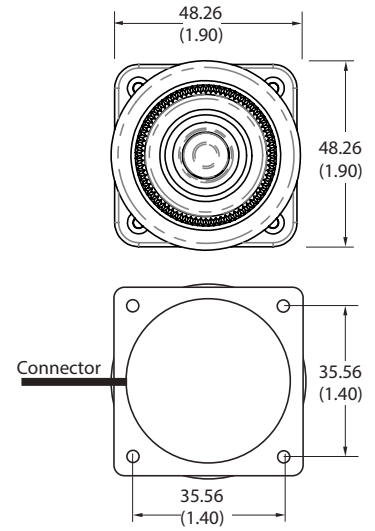
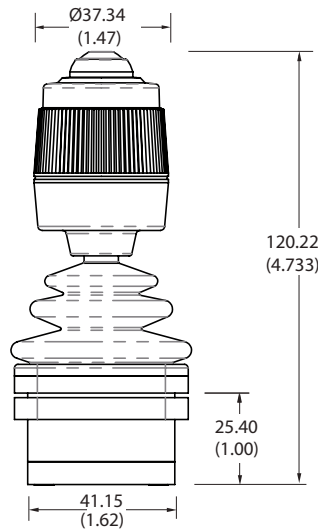

Handle D

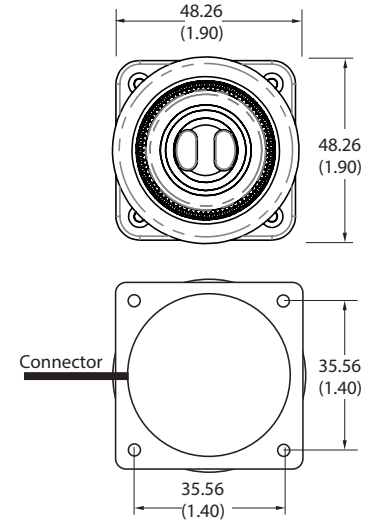
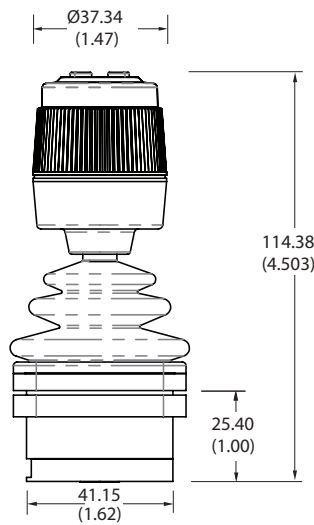

Handle E

Drop-In mounting only

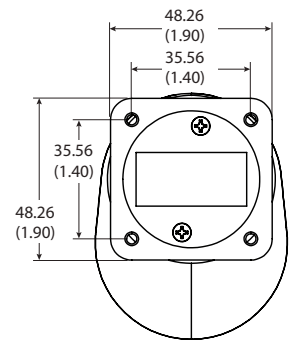
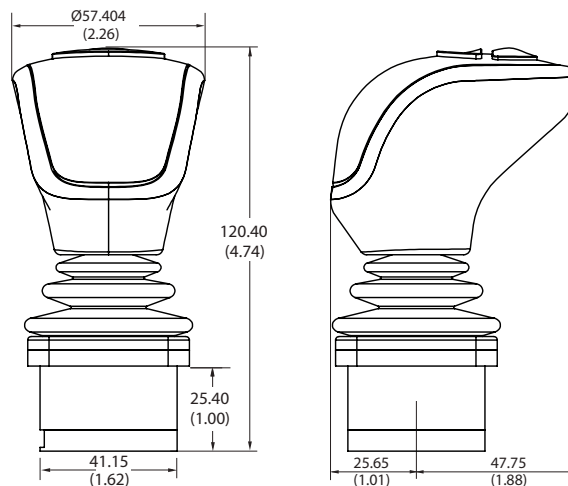

All dimensions in mm (inches)

Mounting Options

Drop-In Option „Mounting 1“

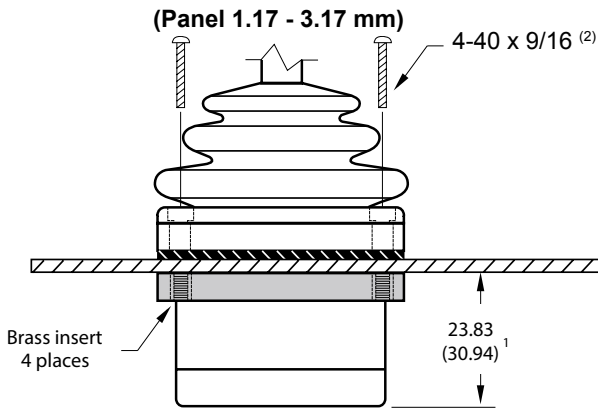

Rear Mount Option „Mounting 2“

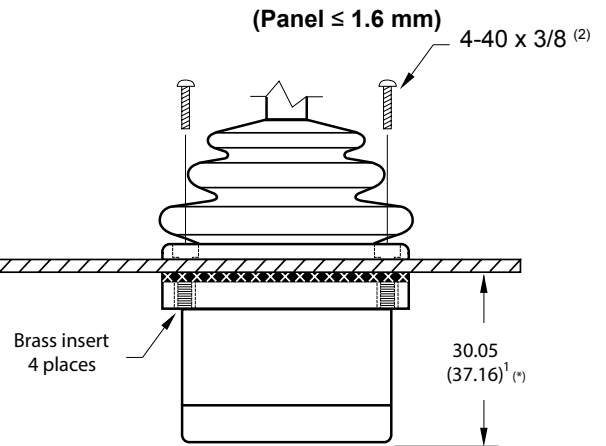

- Panel
- Gasket
- Rear Mount Gasket

(*) at panel thickness 1.6 mm

⁽¹⁾ Below-panel depth is extended by 7.11 mm with USB, Voltage Regulator, Dual Decode, Center Detect options.

⁽²⁾ 4 pcs of mounting screws supplied with each joystick.

Clamping ring

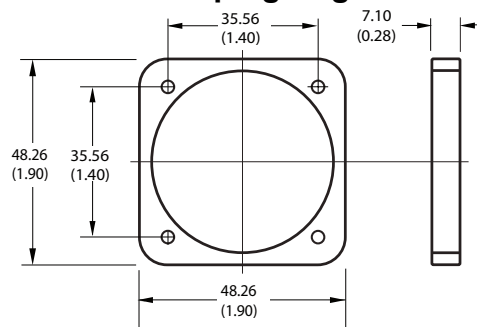

Drop-In Option „Housing 1“

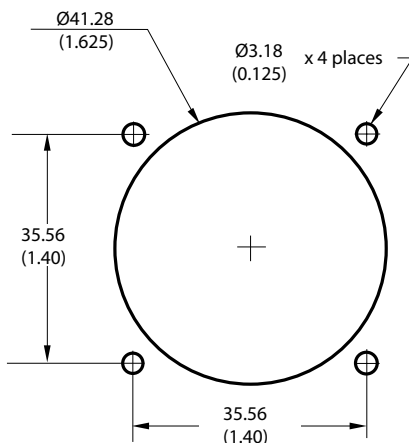

Rear Mount Option „Housing 2“

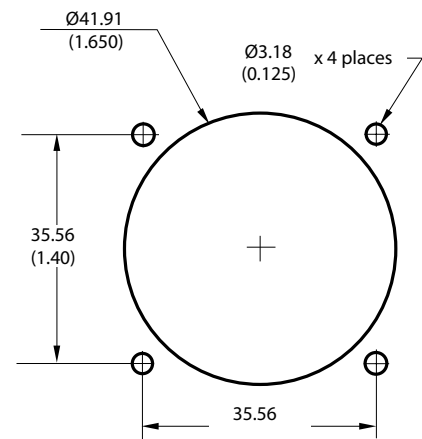

All dimensions in mm (inches)

Data Sheet for Joysticks

Finger Joystick

Series TRY100

Technical Data CAN bus version

Supply Voltage	6 V to 35 V
Current Consumption	Typical: 35 mA @12 V, 18 mA @24 V, 15 mA @30 V
Reverse connection protected	Yes
Short-circuit protected against +UB max.	Yes
Short-circuit protected against GND	Yes
CAN bus standards	ISO 11898, CAN specification 2.0A/2.0B
Protocols	CANJ1939, CANJ1939-71, CANopen*
Baud rate*	125 kbit/s, 250 kbit/s, 500 kbit/s, 1 Mbit/s
CAN ID formats	11 bit (CAN 2.0A) / 29 bit (CAN 2.0B)
BJM/EJM cycle time	50 ms (standard; 15 ms optional)
Terminating resistor	Optional
Operating / Storage Temperature	-40 °C to +85 °C / -40 °C to +85 °C

*Baud rate must be specified when ordering (see order description)

Wiring CAN

Color	Function	Color	Function	Color	Function
Red	Supply Power	Green	CAN High data	Blue	Identifier Select LSB
Black	Ground GND	White	CAN Low data	Orange	Identifier Select MSB

Cable: 22AWG, PTFE, Length ca. 45 cm (specific lengths and connectors upon request)

Technical Drawing

Below panel dimensions
for CAN-bus configurations

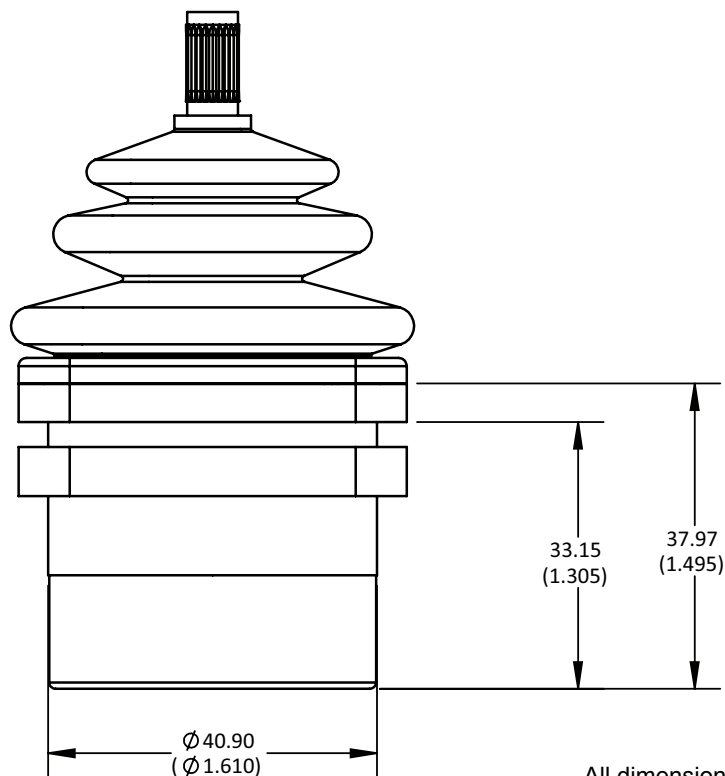

All dimensions in mm (inches)

Data Sheet for Joysticks

Finger Joystick

Series TRY100

Option Desktop Housing



Color of the Desktop Housing is black (handle and pushbuttons black).

With integrated USB controller a maximum of 4 pushbuttons (handle + desktop housing) can be controlled. Please do not hesitate to contact us if you need a different configuration for your project.

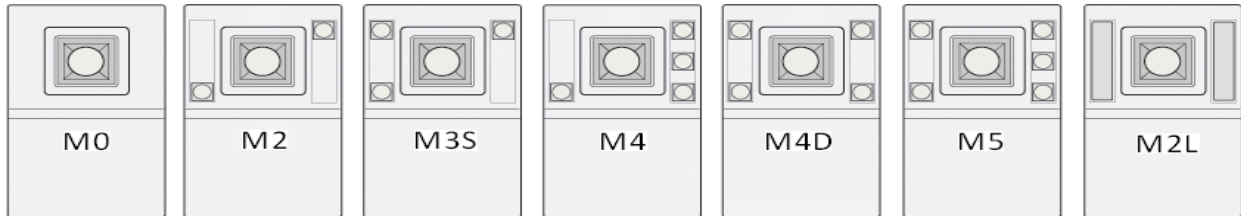

Dimensional Drawing Desktop Housing

