

Data Sheet for Angle Sensors

Optical Encoders

Series MOL30



- Optical resolution 10 to 3000 Impulse / 360°
- Metal housing, ball bearing
- 30 mm housing diameter
- 4 mm shaft diameter
- Output: NPN, Open Collector, Linedriver, Push Pull
- 2 m signal cable
- Shaft coupling included in delivery

The robust encoder design of the MOL30 series is particularly suitable where high operational shaft speeds and a long service life paired with compact housing dimensions are required. The MOL30 is established on the market for many years in hundreds of applications and is a guarantor of high reliability. The linedriver option provides a reliable measurement value transmission over long distances between encoder and evaluation unit.

Electrical Data	Push Pull "B"	Open Collector "K"	Voltage Output "NPN"	Line Driver "N"
Output channels	A, B, Z			A, A/, B, B/, Z, Z/
Number of pulses	100..3000 pulses per revolution			
Output voltage high	Residual voltage 0.4 VDC	Residual voltage max. 0.4 VDC	Residual voltage max. 0.4 VDC	Output voltage min. 2.5 VDC
Output voltage low	Output voltage VSUP 5 VDC: min. VSUP -2.0 VDC Output voltage VSUP 12..24 VDC: min. VSUP -3,0 VDC			Residual voltage max. 0.5 VDC
Limit frequency	300 kHz			
Supply voltage	5 VDC ±5 % 12..24 VDC ±5 %			5 VDC ±5 %
Current consumption (no load)	≤ 80 mA			≤ 50 mA
Output load	(High) max. 30 mA (Low) max. 10 mA	max. 30 mA	max. 10 mA	(High) max. -20 mA (Low) max. 20 mA
Insulations voltage 1.)	≥ 100 MOhm @ 500 VDC			
Insulation resistance 1.)	750 VAC (1 min.)			
Output electronics	Push Pull	Open Collector	Voltage Output NPN	Linedriver
Switch-on delay	max. 1 µs (5V) / max. 2 µs (12..24 V)	max. 1 µs		max. 0,5 µs

Data Sheet for Angle Sensors

Optical Encoders

Series MOL30

Mechanical and Environmental Data, Miscellaneous

Mechanical angle of rotation/stroke 1.)	360° without stop
Bearing	Ball bearing
Max. operational speed	5000 rpm
Operational torque @ RT 1.) 2.)	≤ 0,2 Ncm
Operating temperature range	-10..+70 °C
Storage temperature range	-25..+80 °C
Protection grade (IEC 60529) standard	IP50
Vibration (IEC 68-2-6, Test Fc)	10..55 Hz (1 min.); 1.5 mm; each 2 h in X, Y, Z
Shock (IEC 68-2-27, Test Ea)	max. 50G
Housing diameter	30 mm
Housing depth	28.5 mm
Shaft diameter	4 mm
Shaft type	Solid shaft
Max. radial load	< 19.61 N
Max. axial load (thrust)	< 9.81 N
Connection type	Standard: round cable 2 m, Ø5mm (standard: 6 pol., linedriver: 8 pol.) Option: 250 mm, Ø5mm signal cable with plug (standard: 6 pol., linedriver: 8pol.)
Connection position	Axial
Sensor mounting	Threaded holes in the sensor front (screws not included in delivery)
Mass	app. 80 g
Fastening parts included in delivery	none
Fastening parts included in delivery	Ø4 mm shaft coupling
Material shaft	Stainless steel
Material housing	Aluminium
Material disc	Plastic
Immunity ESD	± 4 kV (standard)

1.) According IEC 60393

2.) Determined by climatic conditions according to IEC 68-1, para. 5.3.1 without load collectives

Data Sheet for Angle Sensors

Optical Encoders

Series MOL30

Order Code

Description		Selection: standard=black/bold, possible options=grey/cursive					
Series	MOL30						
Shaft diameter: Ø4 x 11.5 mm <i>Option shaft length in mm</i> <i>Option shaft diameter in mm (≤4 mm)</i>		- <i>Ax,xx</i> <i>Dx,xx</i>					
Resolution in pulses per revolution: <i>Option 100 ppr.</i> <i>Option 200 ppr.</i> 360 ppr. 500 ppr. <i>Option 1000 ppr.</i> 1024 ppr. <i>Option 3000 ppr.</i>			100 200 360 500 1000 1024 3000				
Supply voltage: 12..24 V (Push-Pull, NPN, Open Collector) <i>Option: 5 V (Line Driver, Push-Pull, NPN, Open Collector)</i>				1224 5			
Output signal: A+B+Z					BZ		
Output electronics: <i>Option Open Collector</i> <i>Option voltage output</i> <i>Option line driver</i> Push Pull						<i>K</i> <i>NPN</i> <i>N</i> B	
Electrical Connection (axial): Round cable 2 m cable length <i>Option round cable with plug (0.25 m cable length)</i> <i>Option round cable user defined cable length [x,xx meter]</i> <i>Option round cable user defined cable length [x,xx meter] with plug</i>							- <i>ST</i> <i>CVX,XX</i> <i>CVX,XX ST</i>

Order example MOL30

Requirement:

Shaft diameter 4 mm, resolution 360 pulses per revolution, supply voltage 12..24 V, 2 channels A+B and Index, output electronics Push Pull, 2 m signal cable length

Example for order code: MHL40 6 360 5 BZ B

For higher quantities or on-going demand, additional options are available as described below

For example:

- Other resolutions
- Special cable length
- Modified shaft shape
- Special cable and connector design

Data Sheet for Angle Sensors

Optical Encoders

Series MOL30

Technical Drawing

Axial cable type

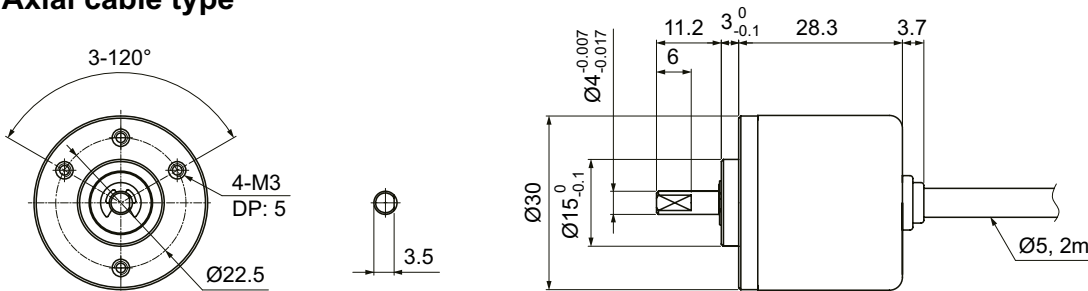

Cable for axial cable type

Ø5, 5-wire (line driver output: 8-wire),
2m, Shield cable

Axial cable connector type

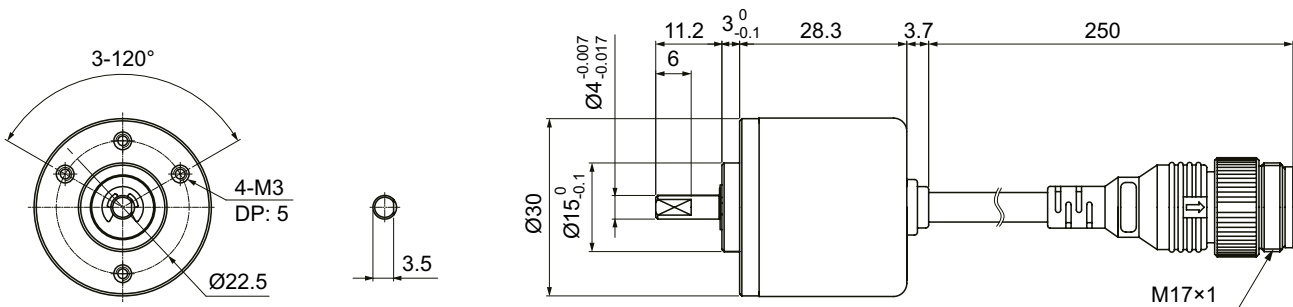

Cable for axial cable connector type

Ø5, 5-wire (line driver output: 8-wire),
250mm, Shield cable

Dimensions in mm

Coupling

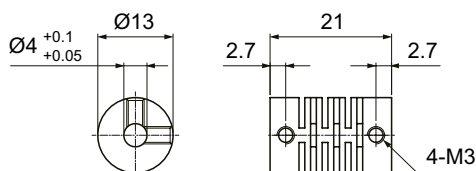

- Parallel misalignment: max. 0.25mm
- Angular misalignment: max. 5°
- End-play: max. 0.5mm

※It must not use larger shaft loading than specification.

※Do not put strong impact when insert a coupling into shaft.

Failure to follow this instruction may result in product damage.

※Fix the unit or a coupling by a wrench under 0.15N·m of torque.

※When you install this unit, if eccentricity and deflection angle are larger, it may shorten the life cycle of this unit.

Data Sheet for Angle Sensors

Optical Encoders

Series MOL30

Connections

Axial cable type

- Totem pole output / NPN open collector output / Voltage output

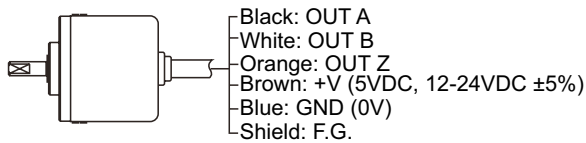

- Line driver output

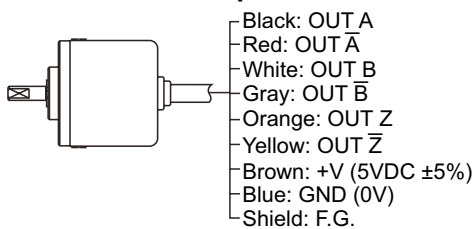

Axial cable connector type

- Totem pole output / NPN open collector output / Voltage output
- Line driver output



Totem pole output NPN open collector output Voltage output			Line driver output		
Pin No.	Function	Cable color	Pin No.	Function	Cable color
①	OUT A	Black	①	OUT A	Black
②	OUT B	White	②	OUT A-bar	Red
③	OUT Z	Orange	③	+V	Brown
④	+V	Brown	④	GND	Blue
⑤	GND	Blue	⑤	OUT B	White
⑥	F.G.	Shield	⑥	OUT B-bar	Gray
—			⑦	OUT Z	Orange
			⑧	OUT Z-bar	Yellow
			⑨	F.G.	Shield

※F.G. (field ground): It should be grounded separately.

- ※Unused wires must be insulated.
- ※The metal case and shield wire of encoder should be grounded (F.G.).
- ※Do not apply tensile strength over 30N to the cable.

Control output diagram

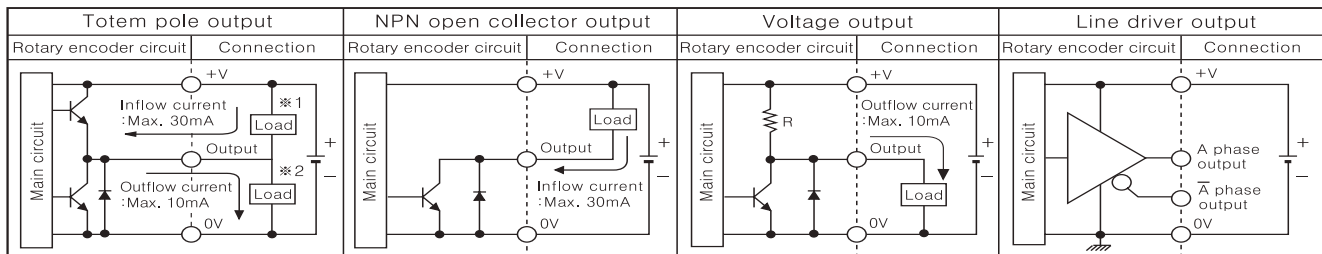

Totem pole output type can be used for NPN open collector output type (*1) or Voltage output type (*2). All output circuits of A, B, Z phase is same. (Line driver output is for A, A-bar, B, B-bar, Z, Z-bar)

Output waveform

