

Data Sheet for Angle Sensors

Hall-Effect Singleturn Rotary Encoder with incremental output

Series ETI25



ETI25 - R



ETI25 - F

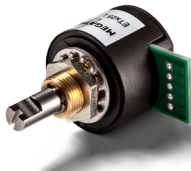

ETI25 - L

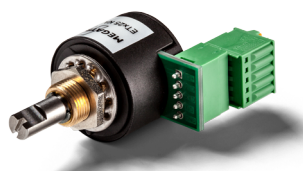

ETI25 - K

- Up to 1024 pulses per revolution (4096 steps)
factory programmable 1..128 ppr, 256 ppr, 512 ppr
- Versatile connecting possibilities:
Solder- or clamping terminals, flat ribbon or round cable
- Electrical Interfaces Push-Pull, Open-Collector, TTL
- Compact Ø25 mm housing
- Simple to mount bushing design

Electrical Data

Output Signal	TTL	Push-Pull	Open Collector	
Number of pulses	1024, 512, 256, 1-128 Imp./Rev.			
Limit frequency	100 kHz			
Switch-on delay	20 ms			
Supply voltage	3,3 VDC ±10%	5 VDC ±10%	10...30 V	10...30 V
Power consumption (no load)	≤ 15 mA		≤ 50 mA	≤ 25 mA
Output load	≥ 5 kOhm			
Max. Pull-Up Voltage			30 VDC	
Insulation voltage ^{1.)}	1000 VAC @ 50 Hz, 1 min			
Insulation resistance ^{1.)}	2 MOhm @ 500 VDC, 1 min			

Mechanical and Environmental Data

Life time ^{2.)}	> 100 Mio. shaft rotating movements For Option D (with shaft sealing) the sealing is at least working up to 200 000 shaft rotating movements
Bearing	Sleeve bearing
Max. operational speed	100 rpm (< 1 min 800 rpm)
Operational torque without / with X-Ring	0,1 ≤ M ≤ 0,6 Ncm / 0,3 ≤ M ≤ 1,3 Ncm (@ RT, 10 rev./min)
Operating Temperature range	-40..+85 °C (fixed cable)
Storage temperature range	-40..+105 °C
Protection grade front side (IEC 60529)	
Standard	IP40
Option D (with shaft sealing)	IP55M, IP66S
Protection grade rear side (IEC 60529)	
Solder- and clamping terminals	IP50 (solder pads and connectors excluded)
Flat ribbon - and round cable	IP66 (end of cable excluded)
Vibration (IEC 68-2-6, Test Fc)	±1,5 mm / 20 g / 10 bis 2000 Hz / 16 frequency cycles (3x4 h)
Mechanical shock (IEC 68-27, Test Ea)	50 g / 11 ms / half-sine (3x6 shocks)

Data Sheet for Angle Sensors

Hall-Effect Singleturn Rotary Encoder with incremental output

Series ETI25

Max. radial load	1 N
Mass (product with option L)	Approx. 26 g
Fastening parts included in delivery	Hex nut (AF14) and tooth washer, if option D is ordered then an additional O-Ring is part of delivery as sealing between mounting panel and rotary encoder.
Fastening torque mounting nut	≤ 3 Nm
Material shaft	Stainless steel
Material housing	Plastic / Bronze

Immunity

EN 61000-4-2 ESD	Class B
EN 61000-4-3 RF sine wave	Class A
EN 61000-4-6 Conducted sine wave	Class A
EN 61000-4-8 Power frequency magnetic fields	Class A

1.) According IEC 60393

2.) Determined by climatic conditions according to IEC 68-1, para. 5.3.1 without load collectives

Further information

Relationship between anti rotation pin and effective electrical angle

Option anti rotation pin A	If shaft flattening is facing antirotation pin A then index signal (Z) will be output.
Option anti rotation pin B	If shaft flattening is facing antirotation pin B then index signal (Z) will be output.

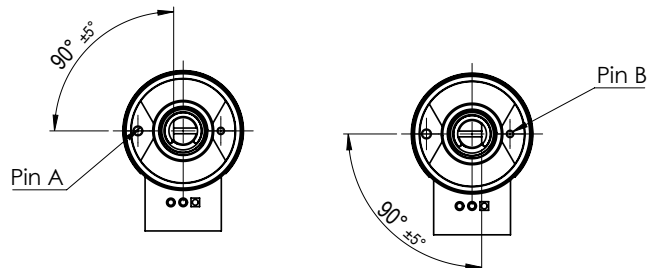

Data Sheet for Angle Sensors

Hall-Effect Singleturn Rotary Encoder with incremental output

Series ETI25

Order Code										
Description		Selection: standard=black/bold, possible options=grey/cursive								
Series ETI25	ETI25									
Shaft diameter, shaft length: Shaft diameter Ø 6 mm, shaft length 22 mm Option: Shaft diameter Ø 6.35 mm, shaft length 22 mm Option: User defined shaft [mm] Ø ≤6.35mm		6x22								
		<i>6.35x22</i>								
		<i>XxXX</i>								
Number of pulses (pulses per revolution): 1024 Option: 512 Option: 256 Option: 128 Option: user defined pulses (<128)				1024						
				<i>0512</i>						
				<i>0256</i>						
				<i>0128</i>						
				<i>0XXX</i>						
Supply voltage / Output signal: VSUP=24 V (10...30 V) / OUT=A, B, Z, Push-Pull VSUP=24 V (10...30 V) / OUT=Open Collector VSUP=5 V ± 10% / OUT=A, B, Z, TTL VSUP=3,3 V ± 10% / OUT=A, B, Z, TTL (only for options L or K with 256, 128, 64 or 32 impulses available)						24BZPP				
						24BZOC				
						05BZTTL				
						3.3BZTTL				
Shaft sealing (standard without shaft sealing): Option: D with shaft sealing								<i>D</i>		
Electrical connection, cable length, anti rotation pin (according drawing) Standards: Flat ribbon cable standard length 0.15 m (anti rotation pin compatible to former series ENA22, anti rotation pin option B) Round cable 1m [x.xx m] (anti rotation pin compatible to former series ENA22, anti rotation pin B)									F0.15B	
									R1.00B	
Electrical connection, cable length, anti rotation pin (according drawing): Options: Electrical connection: Option: solder pads Option: clamping Terminals Option: flat ribbon cable Option: round cable Cable length: Option: cable length in user defined length [x,xx m] (only for option F and R, flat ribbon cable ≤ 3 m) Anti rotation pin: Option: anti rotation pin A (anti rotation pin compatible to former series MAB25A) Option: anti rotation pin B (anti rotation pin compatible to former series ENA22A)									<i>L</i>	
									<i>K</i>	
									<i>F</i>	
									<i>R</i>	
										<i>X.XX</i>
										<i>A</i>
										<i>B</i>

Order example ETI25

Requirement:

Shaft Ø 6.00 mm, shaft length 22 mm, number of pulses 1024 TTL output, VSUP=5 V/TTL, no shaft sealing, flat ribbon cable 0,15 m, anti rotation pin B

Example for order code:

ETA25 6x22 1024 05BZTTL R1.20B

Data Sheet for Angle Sensors

Hall-Effect Singleturn Rotary Encoder with incremental output

Series ETI25

Additional options

For higher quantities or on-going demand, additional options are available as described below on request

For example:

- Output of absolute value by incrementing the signals after power on
- Alteration of the signal sequence and index position
- Special shaft design
- Special operational torque
- Special cable assembly, cable length

Data Sheet for Angle Sensors

Hall-Effect Singleturn Rotary Encoder with incremental output

Series ETI25

Drawing

Option L

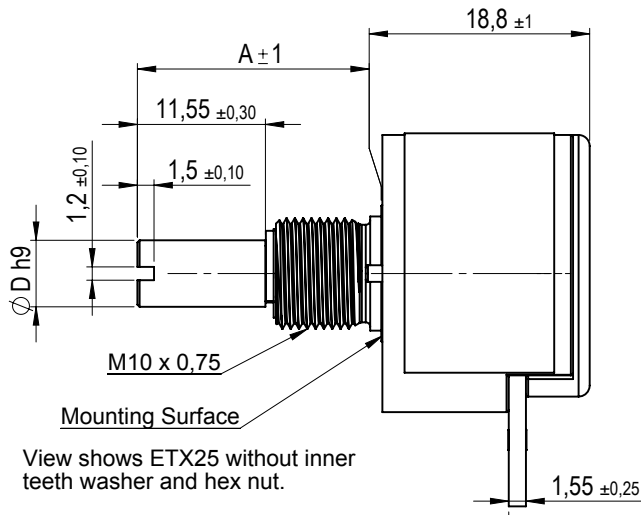

Standard shaft dimensions	
Shaft length A	22 mm
Shaft diameter D	6 mm

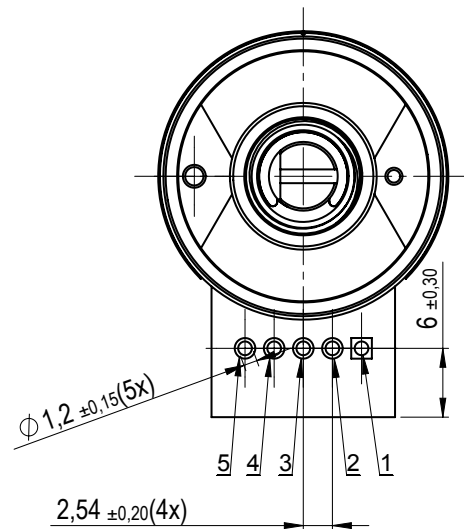
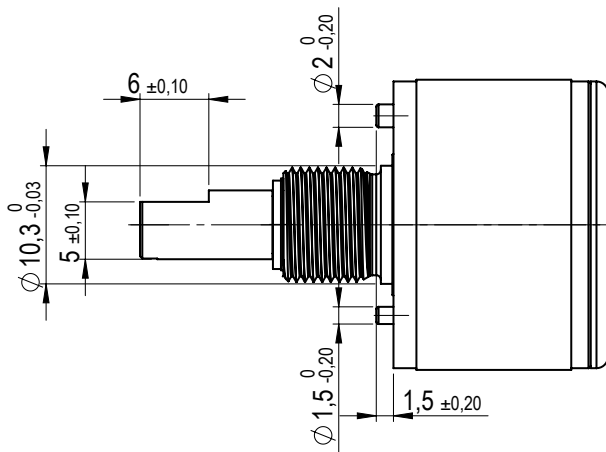

Pattern of Drilling

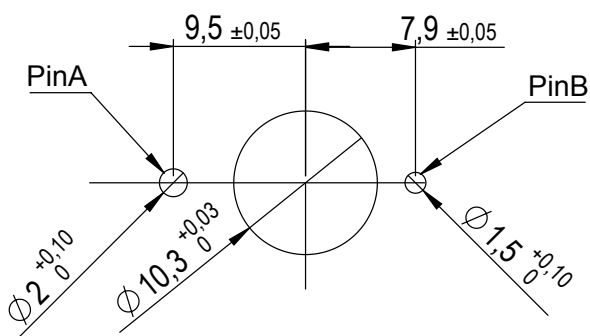

Data Sheet for Angle Sensors

Hall-Effect Singleturn Rotary Encoder with incremental output

Series ETI25

Drawing

Option K

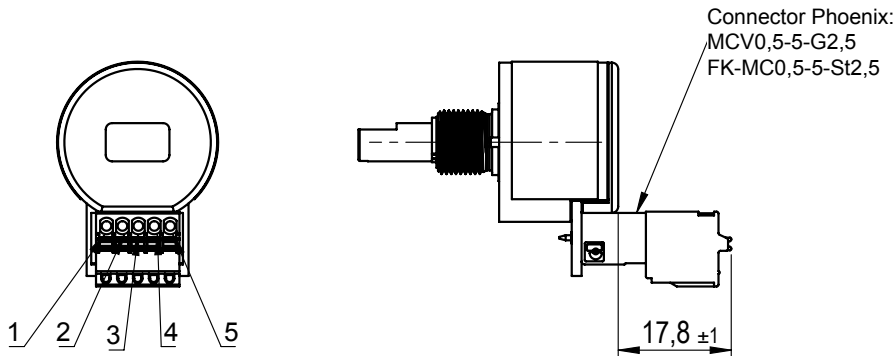

Option R

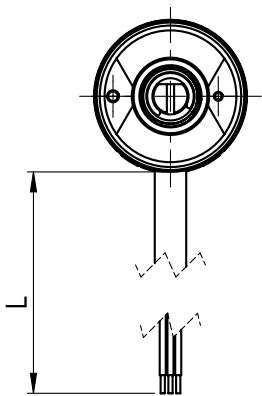

Option F

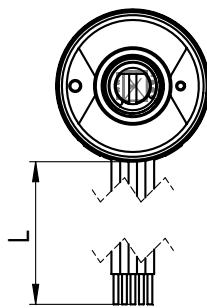

1=red marking

Option	Standard Cable Length L	Cable Cross Section	Allowed Tolerance
R	1000 mm	AWG26	-20 mm...+40 mm
F	150 mm	AWG26	-10 mm...+25 mm

(*) Tolerances according IPC Association

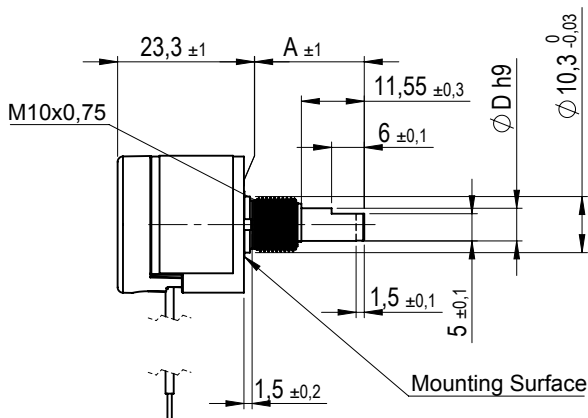

Drawing is applicable for option F and R

Data Sheet for Angle Sensors

Hall-Effect Singleturn Rotary Encoder with incremental output

Series ETI25

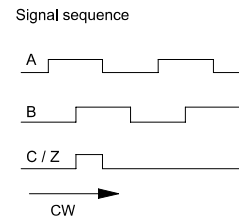
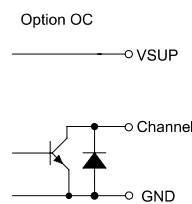
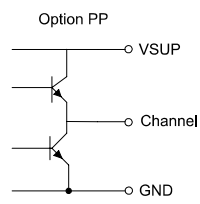
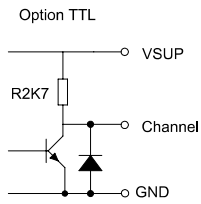

Cable and pin assignment for option L, K

Option L and K:	Function: Push-Pull, TTL, Open Col
PIN 1	VSUP
PIN 2	GND
PIN 3	A
PIN 4	B
PIN 5	Z

Cable and pin assignment for option F

Option F	Function: Open Col, TTL	Function: Push-Pull
Lead 1 (red)	VSUP	VSUP
Lead 2	GND	Z
Lead 3	A	B
Lead 4	B	A
Lead 5	Z	GND

Cable and pin assignment for option R

Option R	Function: Push-Pull, TTL, Open Col
red	VSUP
black	GND
brown	A
orange	B
yellow	Z
green	NC